

Narrow VDC Regulator/Charger with SMBus Interface

The ISL6258, ISL6258A are a highly integrated Narrow VDC system voltage regulator and battery charger controller. Operating parameters are programmable over the System Management Bus (SMBus). The ISL6258, ISL6258A are designed for applications where the system power source is either the battery pack or the output of the regulator/charger. This makes the max voltage to the system equal to the max battery voltage instead of the max adapter voltage. The ISL6258, ISL6258A also include a system to control trickle charging deeply discharged batteries while maintaining system voltage at a user defined minimum. High efficiency is achieved with a DC/DC synchronous-rectifier buck converter, equipped with diode emulation for enhanced light load efficiency and AC adapter boosting prevention. The ISL6258, ISL6258A can charge two to four series connected Lithium-ion cells, at up to 8A charge current. The ISL6258 has default settings for 2-cell systems and ISL6258A has default settings for 3-cell systems. Integrated MOSFET drivers and bootstrap diode result in fewer components and smaller implementation area. Low offset current-sense amplifiers provide high accuracy.

The ISL6258, ISL6258A provide two open drain digital outputs that indicate the presence of the AC adapter and trickle charge state. Trickle charge state and AC adapter present indicators are also available via SMBus. The ISL6258, ISL6258A also provide two analog outputs that indicate the adapter current and battery discharge current with 4% accuracy.

Pinout

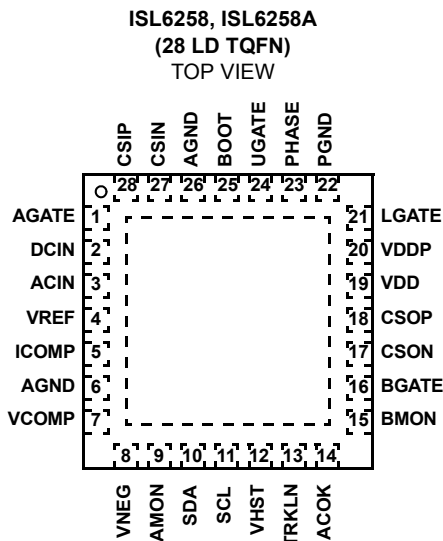

Features

- ±0.5% System Voltage Accuracy (-10°C to +100°C)
- ±3% Accurate Input Current Limit
- ±3% Accurate Battery Charge Current Limit
- Switching frequency can be reduced via SMBus for higher efficiency at light load conditions
- Trickle Charge System for Deeply Discharged Batteries
 - Automatic Trickle Charge Current (256mA)
 - Holds Minimum Voltage to System
- SMBus 2 Wire Serial Interface
- Battery Short Circuit Protection
- Fast System-Load Transient Response
- Monitor Outputs
 - Adapter Current (2.5% Accuracy)
 - Battery Discharge Current (4% Accuracy)
 - Trickle Charge Mode Indicator
 - AC Adapter Present Indicator
- 11-Bit Max System Voltage Setting
- 7-Bit Min System Voltage Setting
- 6-Bit Charge Current Setting
- 6-Bit Adapter Current Setting
- Over 8A Battery Charger Current
- Over 8A Maximum Adapter Current
- +8V to +22V Adapter Voltage Range
- Pb-Free (RoHS Compliant)

Applications

- Notebook Computers
- Tablet PCs
- Portable Equipment with Rechargeable Batteries

All Intersil U.S. products are manufactured, assembled and tested utilizing ISO9001 quality systems.
Intersil Corporation's quality certifications can be viewed at www.intersil.com/design/quality

Intersil products are sold by description only. Intersil Corporation reserves the right to make changes in circuit design, software and/or specifications at any time without notice. Accordingly, the reader is cautioned to verify that data sheets are current before placing orders. Information furnished by Intersil is believed to be accurate and reliable. However, no responsibility is assumed by Intersil or its subsidiaries for its use; nor for any infringements of patents or other rights of third parties which may result from its use. No license is granted by implication or otherwise under any patent or patent rights of Intersil or its subsidiaries.

For information regarding Intersil Corporation and its products, see www.intersil.com